

Symbolische Darstellung  
Symbolic Illustration

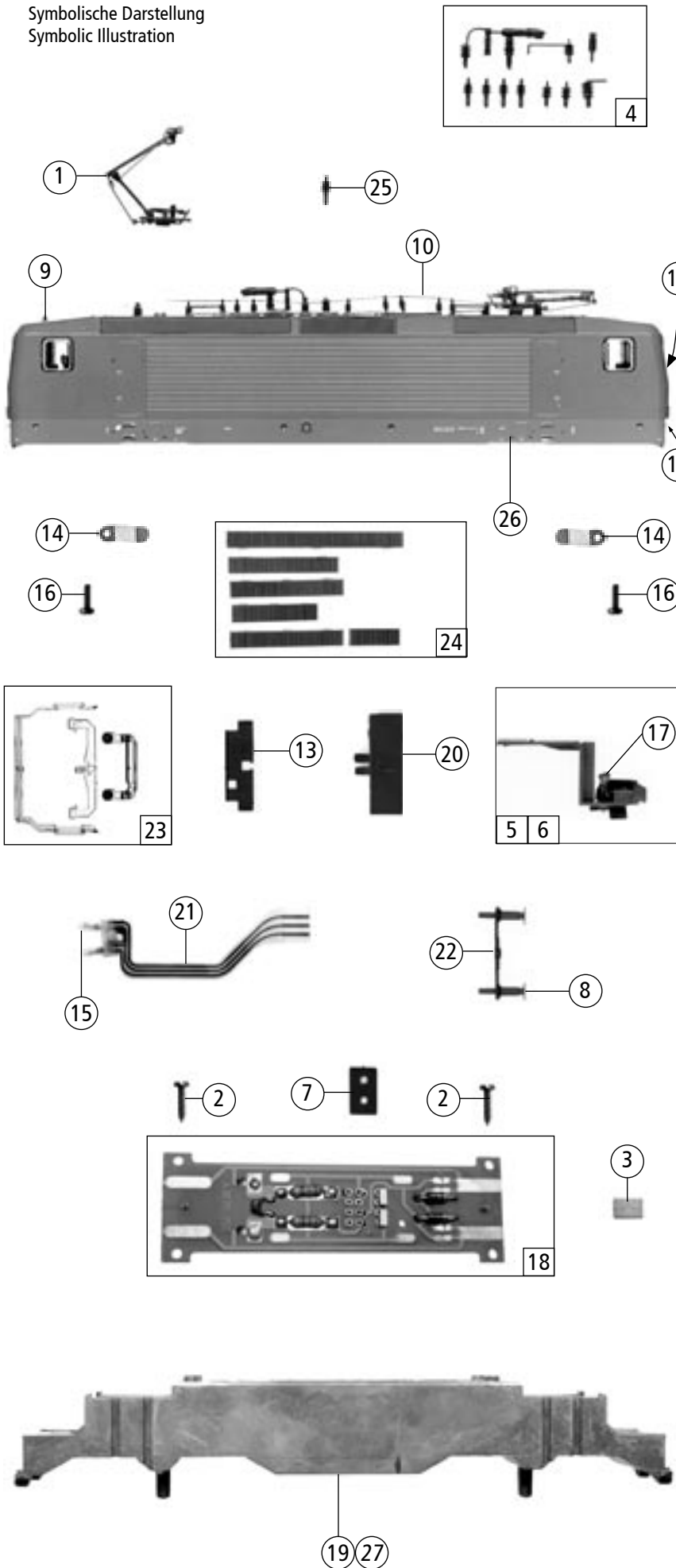

Pos. Nr. Pos.no.	Beschreibung Description	Art.-Nr. Art.no.	Preisgruppe Price bracket
63814	DB	114	=
69814		~	
1	Stromabnehmer Pantograph	85407	38
2	Schraube 2.2X9.5 Screw 2.2x9.5	85808	2
3	Gummibettung Rubber Enbedding	89728	3
4	Isolatorsatz Insulator set	100245	18
5	Führerstandbaugruppe ohne loch Drivers cab without loco driver	100487	12
6	Führerstandbaugruppe mit loch Drivers cab with loco driver	100488	20
7	Brückenstecker Bridge connector	100644	7
8	Puffer eckig Buffer angular	107419	3
9	Antenne Antenna	107429	2
10	Hauptleitung Roof wire	107431	10
11	Steckdose Wall outlet	107433	2
12	Trittbrett silber Running board	107438	2
13	Lichtabdeckung Light cover	107447	2
14	Oberleitungskontakt Overhead supply connector	107805	3
15	Drahtlampe T3/4 16V 30mA Light bulb T3/4 16V 30mA	108616	10
16	Schraube M 1,6X5 Screw M 1.6x5	110008	2
17	E-Lokführer Loco driver	110407	5
18	Platine kpl. Printed circuit assembly	112933	43
19	Grundrahmen Base frame	113431	30
20	Stirnlichtabdeckung Front light cover	113434	2
21	Lampen-Flexplatine Flexible printed circ. for bulbs	115216	20
22	Pufferbohle Headstock	116608	3
23	Fenstersatz Window-/Light transmission set	116613	8
24	Lüftersatz Ventilator set	116614	8
25	Isolator Insulator	116615	2
26	Gehäuse bedruckt Betr. Nr. 114 014-4 Body printed Loco no. 114 014-4	116617	58
~ Wechselstrom AC			
27	Grundrahmen Base frame	113436	30

Änderungen in Konstruktion und Ausführung vorbehalten  
We reserve the right to change the construction and specification

Symbolische Darstellung  
Symbolic Illustration

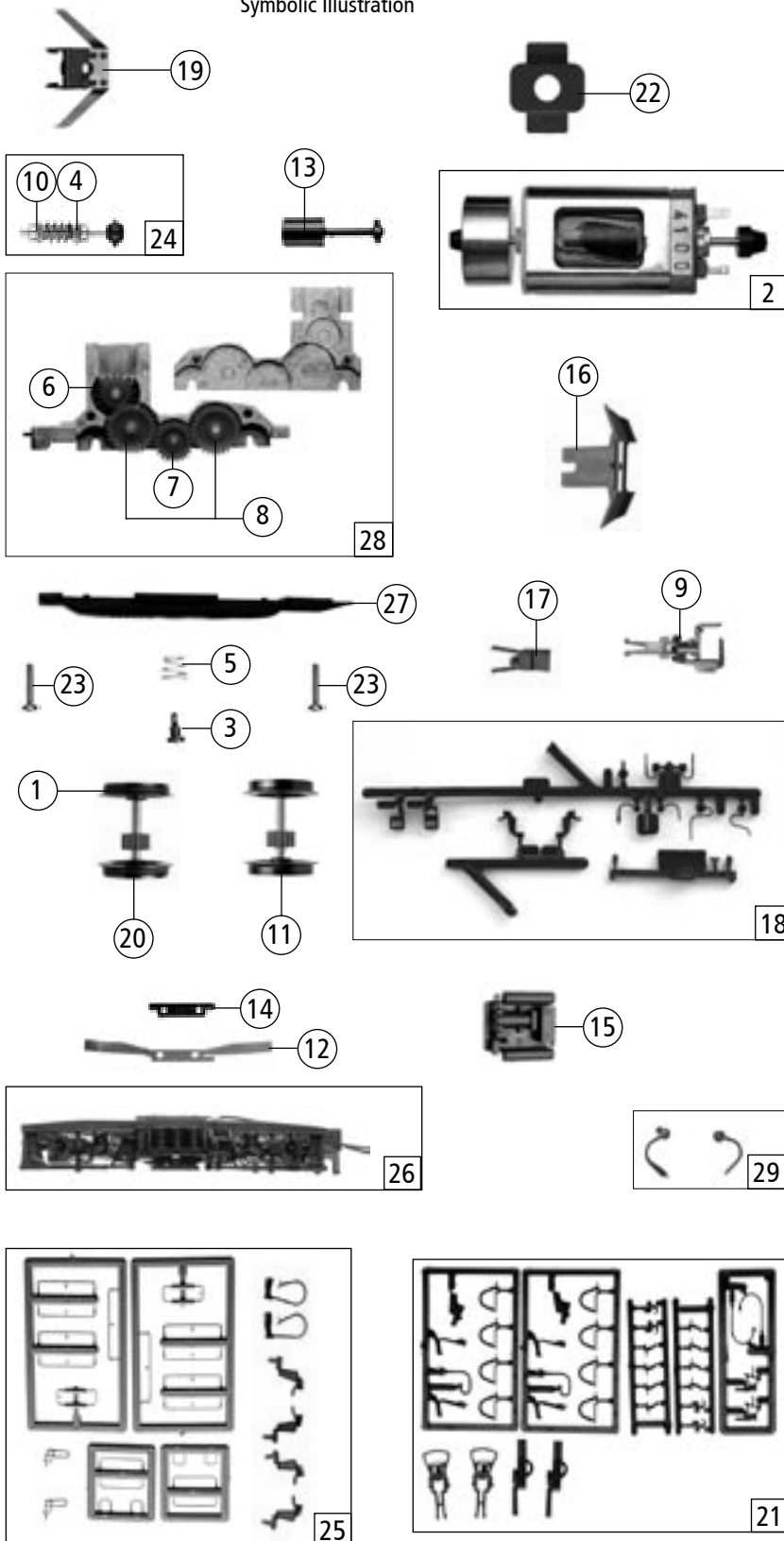

Pos. Nr. Pos.no.	Beschreibung Description	Art.-Nr. Art.no.	Preisgruppe Price bracket
63814	DB	114	=
69814		~	
1	Haftrings.10Stk.12,9-14,6mm Set with traction tires	40070	---
2	Motor Motor	85086	57
3	FK-Schraube M2X4,5/7,5 FK-Screw M2x4.5/7.5	85771	3
4	Beilagscheiben Spacer	86084	2
5	Feder Spring	86202	2
6	Schneckenrad gelb Worm gear yellow	86413	4
7	Zahnrad Z=23 gerade M0,4 Gear Z=23 direct	86425	2
8	Zahnrad Z=29/M-0.4 Gear Z=29/M-0.4	86467	2
9	Universalkupplung Universal coupling	89282	5
10	Lager für Schneckenachse Worm axle bearing	89749	6
11	Radsatz ohne Haftringe Wheelset without traction tires	90828	18
12	Radkontakt Wheel current contact	100256	2
13	Kardanwelle Cardan shaft	100260	3
14	Kontakthalter Contact holder	100485	2
15	Mittelkasten Battery contains	105843	25
16	Schienenräumer Cow calder	105848	3
17	Kupplungskammer Coupling chamber	105849	3
18	Lagerdeckel - Treppensatz Bogieset and stairset	105854	20
19	Schneckendeckel mit Stab.Feder Worm cover with damper	107420	8
20	Radsatz mit 2 Haftringen Wheelset with two traction tires	107423	20
21	Zurüstbeutel Kupplungen Bag with accessories coupling	107436	28
22	Distanzplättchen Spacer	113326	2
23	GF-Schraube M2X6 GF-Screw M2x6	114828	2
24	Schneckensatz Worm set	115224	24
25	Zurüstbeutel Bag with accessories	116609	26
26	Blende kpl. Bogie frame assembly	116610	35
27	Getriebeboden Gear bottom	116611	5
28	Getriebe komplett Gear assembly	116612	24
29	Lagerdeckelsatz Bogie cover set	116618	6

Symbolische Darstellung  
Symbolic Illustration

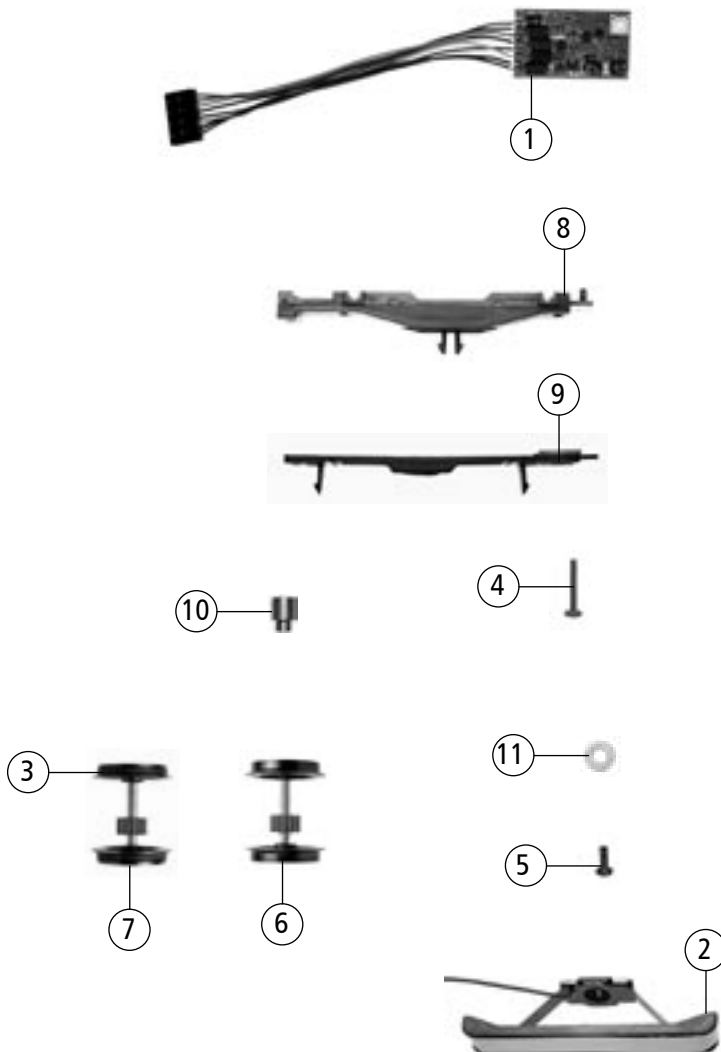

Pos. Nr. Pos.no.	Beschreibung Description	Art.-Nr. Art.no.	Preisgruppe Price bracket
63814	DB	114	=
69814		?	
<b>~ Wechselstrom AC</b>			
1	Decoder Motorola m. Lastr. last. Decoder "Motorola" load reg.	10738	---
2	AC-Flüsterschleifer kurz Whisper wiper, short	40064	---
3	Hafrings.10Stk.12,5-15,3mm Ste with traction tires	40075	---
4	Schraube M1,6X8 Screw M1.6x8	85663	2
5	Schraube M 1,6X4 schw. Screw M1.6x4 black	85727	2
6	Radsatz ohne Hafringe Wheelset without traction tires	90830	16
7	Radsatz mit Hafringen Wheelset with traction tires	90831	20
8	Drehgestellboden Gear bottom	107444	10
9	Drehgestellrahmen Bogie frame	107445	10
10	Anschlussnippel Connection nipple	111116	3
11	Scheibe Spacer	112681	2

Ersatzteile erhalten Sie bei Ihrem Fachhändler,  
oder Ihrer Landesvertretung oder bei:

You can order your Replacement Parts at your  
local dealer, your country representative or:

Roco Modellspielwaren GmbH  
Kundendienst  
Rifer Hauptstraße 21  
A-5400 Hallein

