

Symbolische Darstellung
Symbolic Illustration

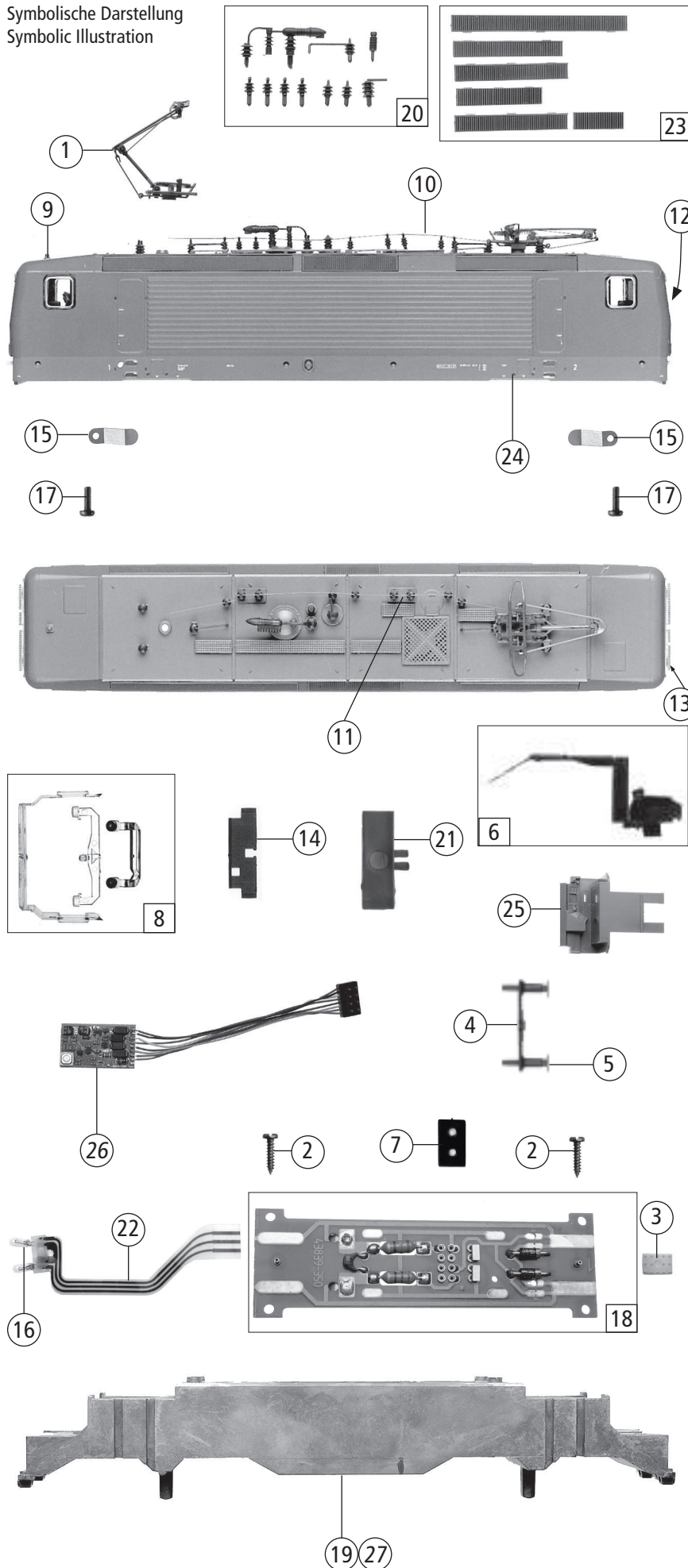

Pos. Nr. Pos.no.	Beschreibung Description	Art.-Nr. Art.no.	Preisgruppe Price bracket
63559	DB 143		
69559		~	
1	Stromabnehmer Pantograph M2X4,5/7,5	85336	38
2	Schraube 2.2X9.5 Screw 2.2x9.5	85808	2
3	Gummibettung Rubber road bed	89728	3
4	Pufferbohle Headstock	100248	3
5	Puffer rund Buffer round	100250	3
6	Führerstandbaugruppe mit Loch Drivers cab with hole	100488	20
7	Brückenstecker Connector	100644	7
8	Fenstersatz Windows set	101376	21
9	Antenne Frontgriff - Auftrittsatz	107429	2
10	Hauptleitung Roof wire	107431	10
11	Platte Plate	107432	2
12	Steckdose Outlet	107433	2
13	Trittbrett silber Running board	107438	2
14	Lichtabdeckung Light cover	107447	2
15	Oberleitungskontakt Overhead supply connector	107805	3
16	Drahtlampe T3/4 16V 30mA Light bulb T3/4 16V 30mA	108616	10
17	Schraube M 1,6X5 Screw M 1,6x5	110008	2
18	Platine komplett Printed circuit	112933	43
19	Grundrahmen Main frame	113431	30
20	Isolatorenset Insulator set	113433	14
21	Stirnlichtabdeckung Front light cover	113434	2
22	Lampen-Flexplatine Bulb printed	115216	20
23	Lüftersatz Lifter set	116614	8
24	Gehäuse komplett Betr.Nr. 143 310-1 Body assembly loco no 143 310-1	117229	73
25	Führerstand Drivers cab	117230	4
Wechselstrom AC ~			
26	Decoder Motorola m.Lastr. last Decoder „Motorola“	10738	---
27	Grundrahmen Main frame	113436	30

Änderungen in Konstruktion und Ausführung vorbehalten
We reserve the right to change the construction and specification

Symbolische Darstellung
Symbolic Illustration

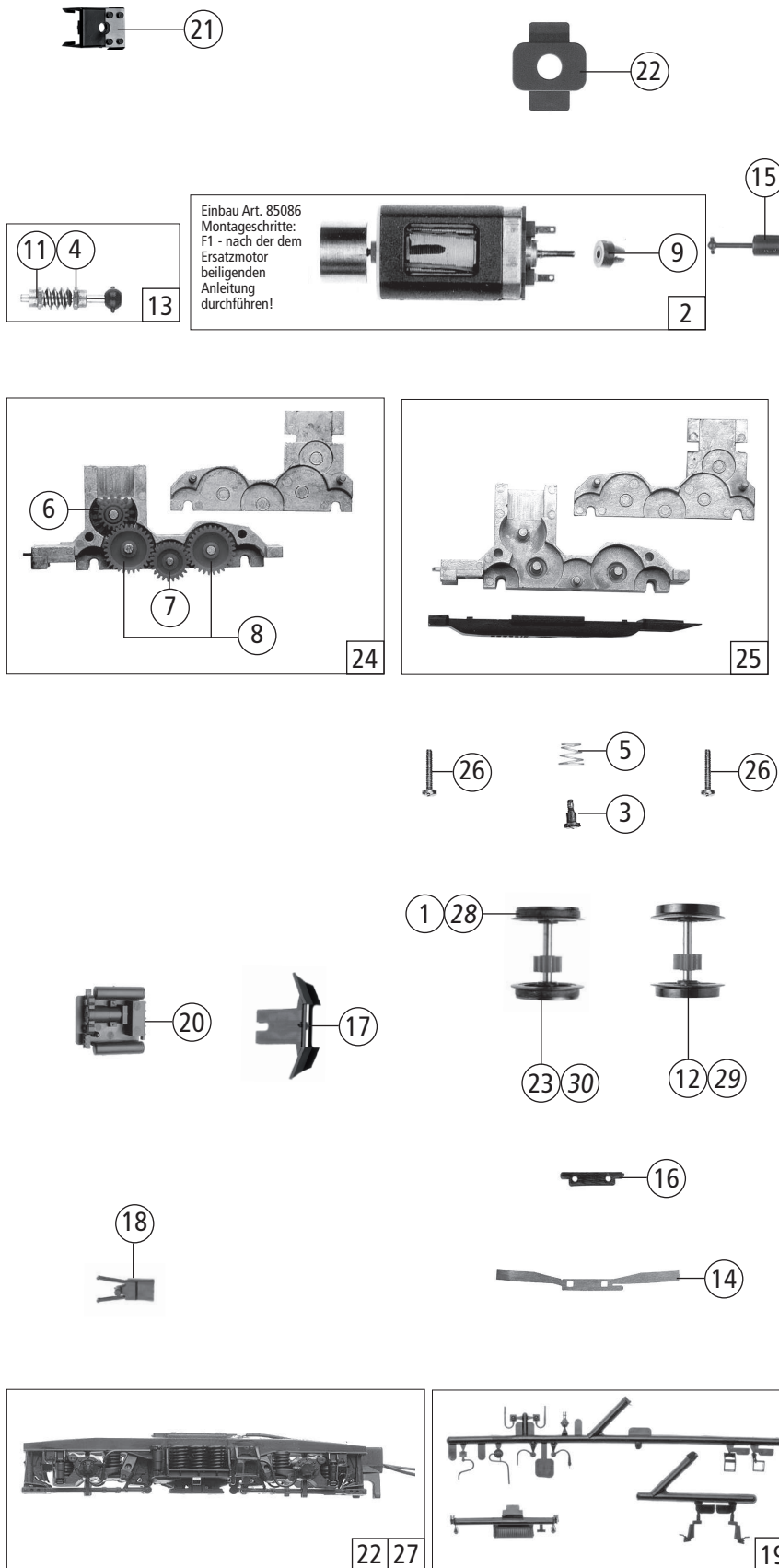

Pos. Nr. Pos.no.	Beschreibung Description	Art.-Nr. Art.no.	Preisgruppe Price bracket
63559	DB 143	=	
69559		~	
1	Haftrings.10Stk.12,9-14,6mm Traction tyre set 10 part 12,9-14,6mm	40070	---
2	Motor Motor	85086	57
3	FK-Schraube m.Gew. M2X4,5/7,5 FK-screw	85771	3
4	Beilagscheibe 2.1X4/0.2 MM Washer 2,1x4 / 0,2 MM	86102	2
5	Feder Spring	86202	2
6	Schneckenzahnrad doppelt Worm gear double	86419	4
7	Zahnrad Z=23 gerade M 0.4 Gear-Z=23 direct M 0.4	86425	2
8	Zahnrad Z=29/M-0.4 Gear	86467	2
9	Kardanschale kurz 1,5mm Cardan bearing short 1,5mm	87129	3
11	Lager für Schneckenachse Rubber road bed	89749	6
12	Radsatz ohne Haftringe Wheelset without traction tyres	90828	18
13	Schneckensatz Worm set	100254	24
14	Radkontakt Wheel contact	100256	2
15	Kardanwelle Cardan shaft	100260	3
16	Kontakthalter Contact holder	100485	2
17	Schienenräumer Rail guard	105848	3
18	Kupplungskammer Coupling chamber	105849	3
19	Lagerdeckel-Treppensatz Bogieset and stairset	105854	20
20	Mittelkasten Battery contains	107418	6
21	Schneckendeckel Wormcover	94707	3
22	Blende 1 kpl. Boogie frame 1 assembly	107422	35
23	Radsatz mit 2 Haftringen Wheelset with 2 traction tyres	107423	20
24	Getriebe komplett Gear box complete	107424	29
25	Getriebebesatz Gear set	107426	24
26	GF-Schraube M2X6 GF-Screw M2x6	114828	2
27	Blende 2 komplett Boogie frame 2 assembly	115222	35
Wechselstrom AC ~			
28	Haftrings.10Stk.12,5-15,3mm Set with traction tires 10 pieces	40075	---
29	Radsatz ohne Haftringe Wheelset without traction tyres	90830	16
30	Radsatz mit Haftringen Wheelset with traction tyres	90831	20

Symbolische Darstellung
Symbolic Illustration

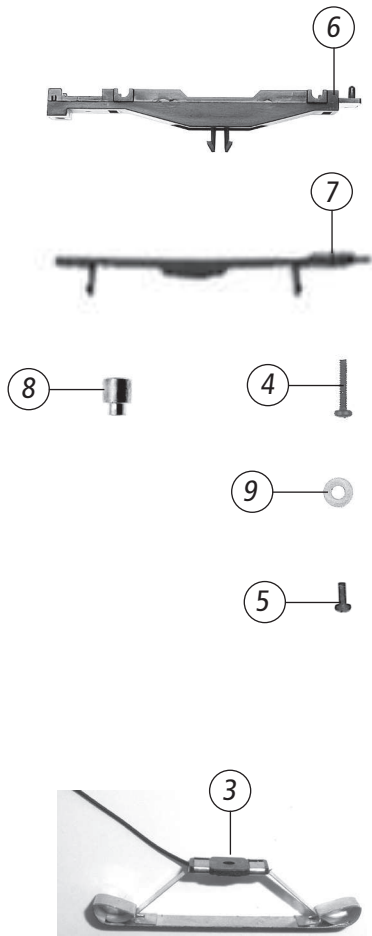

63559		DB	143	
69559		?		
Pos. Nr. Pos.no.	Beschreibung Description	Art.-Nr. Art.no.	Preisgruppe Price bracket	
1	Zurüstbeutel Bag with accessories	107434	26	
2	Zurüstbeutel Kupplungen Bag with accessories coupling	107436	28	
Wechselstrom AC ~				
3	AC-Schleifer kurz AC- wiper short	40500	---	
4	Schraube M1,6x8 Screw M1,6x8	85695	2	
5	Schraube M 1,6x4 schw. Screw M 1,6x4 black	85727	2	
6	Drehgestellboden Gear bottom	107444	10	
7	Drehgestellrahmen Bogie frame	107445	10	
8	Anschlussnippel connection nipple	111116	3	
9	Scheibe Disc	112681	2	

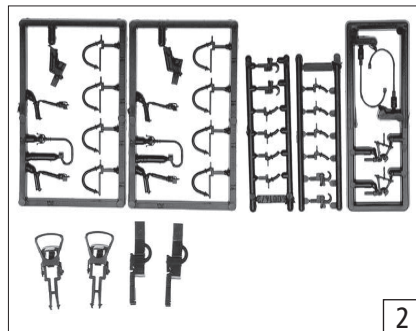
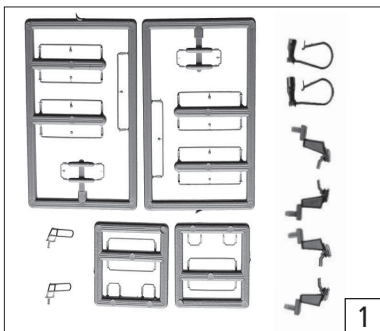

Ersatzteile erhalten Sie bei Ihrem Fachhändler,
oder Ihrer Landesvertretung.

You can order your Replacement Parts at your
local dealer, your country representative.

Pos. Nr.	Text	Art.-Nr.	Preisgruppe
1	Stromabnehmer Pantograph	85336	38
2	Schraube 1,6 x 5 Screw 1,6 x 5	85692	2
3	Schraube 2,2 x 6,5 Screw 2,2 x 6,5	85800	2
4	Platine komplett Printed circuit assembly	87645	43
5	Glühlampe Light bulb	93518	12
6	Glühlampe rot Light bulb red	93522	14
7	Fenster Lichtleitstäbesatz Glazing set	100241	21
8	Lichtabdeckung Light cover	100249	2
9	Umschaltwelle Switch contact	100259	2
10	Grundrahmen Base frame	100486	30
11	Führerstandbaugruppe ohne Lokführer Drivers cab without loco driver	100487	12
12	Führerstandbaugruppe mit Lokführer Drivers cab with loco driver	100488	20
13	Brückenstecker für DC Connector for DC	100644	7
14	Pufferbohle Headstock	105844	3
15	Puffer Buffer	107419	3
16	Gehäuse kpl. Betr. nr. 143 921-5 Body assembly Betr. No. 143 921-5	107421	68
17	Lüftersatz Lifter set	107428	12
18	Antenne Antenna	107429	2
19	Isolatorsatz Insulator set	107430	18
20	Hauptleitung Roof wire	107431	10
21	Platte Plate	107432	2
22	Steckdose Outlet	107433	2
23	Laufstegsatz Gangway set	107437	12
24	Trittbrett silber Running board	107438	2
25	Grundrahmen Base frame	100264	30
26	Platine kpl. Printed circuit	100267	43
27	Brückenstecker Connector	100645	7

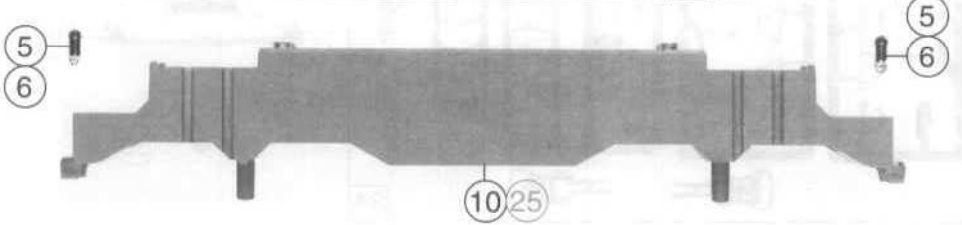
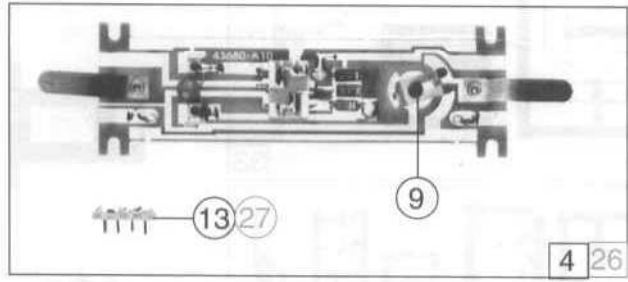
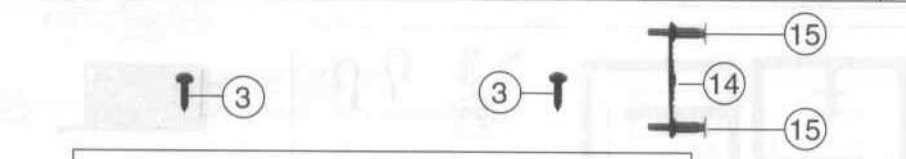
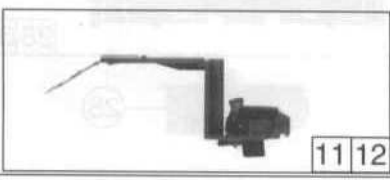
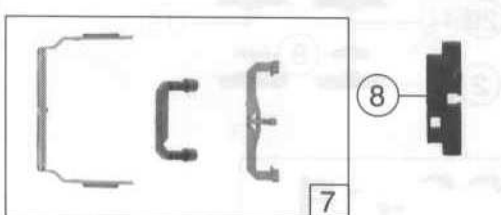
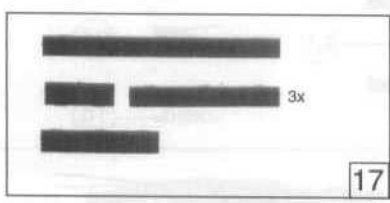
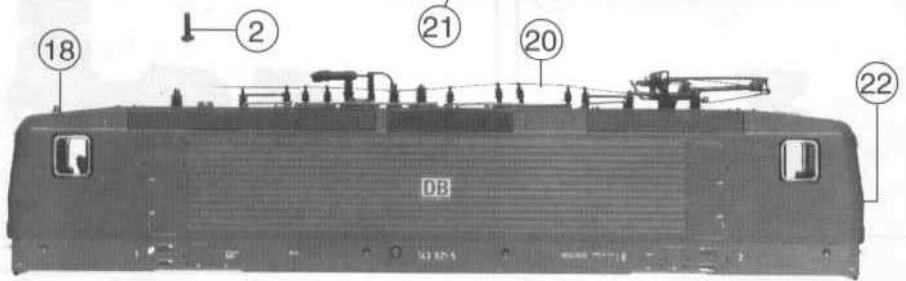
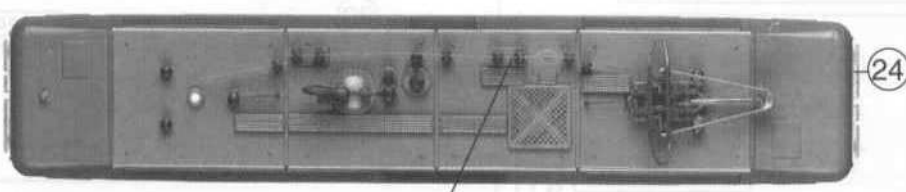
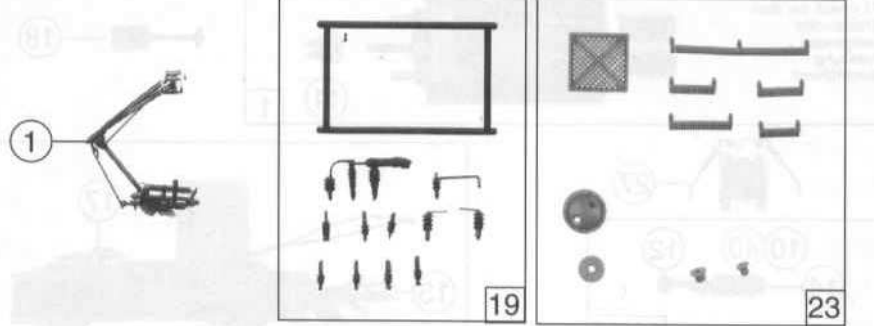

ENT RB 80

Pos. Nr.	Text	Art.-Nr.	Preisgruppe
1	Motor komplett <i>Motor assembly</i>	85086	57
2	Hafttringesatz <i>Traction tyre set</i>	85622	19
3	FK-Schraube <i>Screw</i>	85756	2
4	Schraube M 2 x 6 <i>Screw M 2 x 6</i>	85672	2
5	Feder <i>Spring</i>	86202	2
6	Schneckenrad <i>Gear</i>	86419	4
7	Zahnrad z=23 <i>Gear T=23</i>	86425	2
8	Achszahnrad <i>Gear</i>	86460	2
9	Zahnrad z=29 <i>Gear T=29</i>	86467	2
10	Schnecke <i>Worm</i>	86704	5
11	Kardanschale kurz <i>Cardan bearing short</i>	87129	3
12	Kardankugel <i>Cardan ball</i>	87153	2
13	Universalkupplung komplett <i>Universal coupling assembly</i>	89282	5
14	Lager für Schneckenachse <i>Worm axle bearing</i>	89749	6
15	Radsatz ohne Hafttring <i>Wheelset without traction tyre</i>	90828	18
16	Schneckenstanz <i>Worm set</i>	100254	24
17	Radkontakt <i>Wheel current contact</i>	100256	2
18	Kardanwelle <i>Cardan shaft</i>	100260	3
19	Kontakthalter <i>Contact holder</i>	100485	2
20	Schienenräumer <i>Cow calder</i>	105848	3
21	Kupplungskammer <i>Coupling chamber</i>	105849	3
22	Teilesatz <i>Parts set</i>	105854	20
23	Leiter <i>Ladder</i>	105855	2
24	Drehgestell 1 <i>Bogie assembly</i>	107416	53
25	Drehgestell 2 mit Hafttring <i>Bogie assembly with traction tyre</i>	107417	54
26	Mittelkasten <i>Battery container</i>	107418	6
27	Schneckenendeckel mit Stabilisatorfeder <i>Worm cover</i>	107420	8
28	Blende 1 komplett <i>Bogie 1 assembly</i>	107422	35
29	Radsatz mit 2 Hafttringen <i>Wheelset with 2 traction tyre</i>	107423	20
30	Getriebe komplett <i>Gear assembly</i>	107424	29
31	Blende 2 komplett <i>Bogie frame 2 assembly</i>	107425	35
32	Getriebebesatz <i>Gear part set</i>	107426	24
33	Zurüstbeutel <i>Bag with accessories</i>	107434	26
34	Zurüstbeutel <i>Bag with accessories</i>	107436	28
35	Schiefer kurz <i>Collector short</i>	40003	-
36	Hafttringesatz <i>Traction tyre set</i>	85823	19
37	Schraube 1,6 x 8 <i>Screw 1,6 x 8</i>	85695	2
38	Schraube M 1,6 x 4 <i>Screw M 1,6 x 4</i>	85727	2
39	Schneckenrad <i>Gear</i>	86413	4
40	Schnecke <i>Worm</i>	86702	5
41	Modulhalter <i>Modul holder</i>	89795	6
42	Umschaltmodul <i>Modul</i>	89940	-
43	Radsatz ohne Hafttring <i>Wheelset without traction tyre</i>	90830	18
44	Radsatz mit Hafttringen <i>Wheelset with traction tyre</i>	90831	20
45	Schneckenstanz <i>Worm set</i>	100330	24
46	Drehgestell 1 <i>Bogie assembly 1</i>	107441	53
47	Drehgestell 2 <i>Bogie assembly 2</i>	107442	55
48	Getriebe komplett <i>Gear assembly</i>	107443	29
49	Drehgestellboden <i>Gear bottom</i>	107444	10
50	Drehgestellrahmen <i>Bogie frame</i>	107445	10

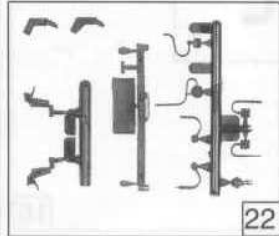
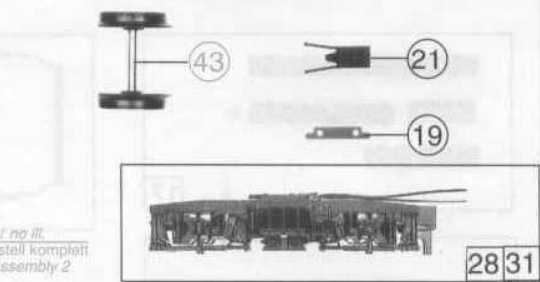
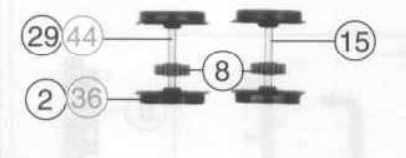
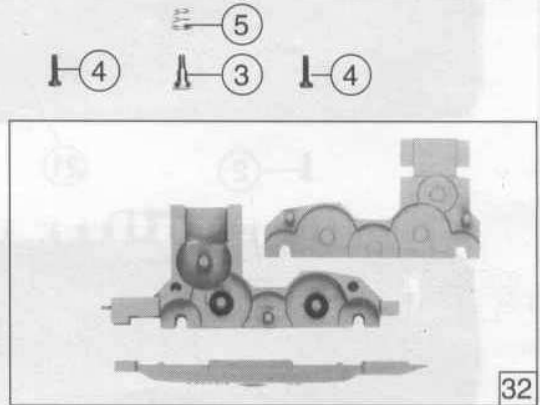
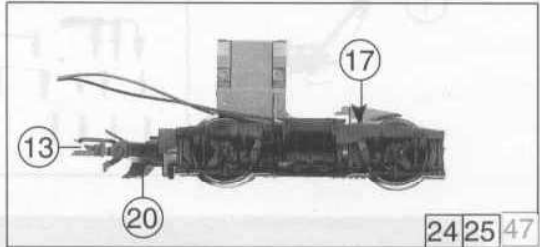
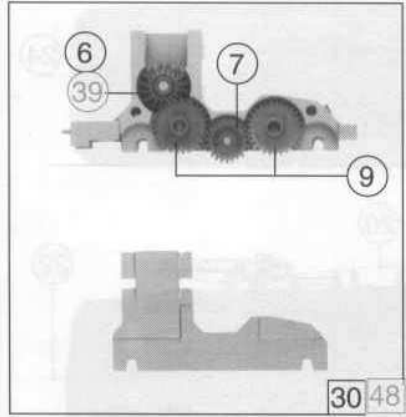
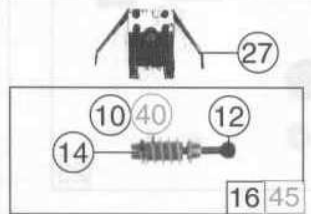
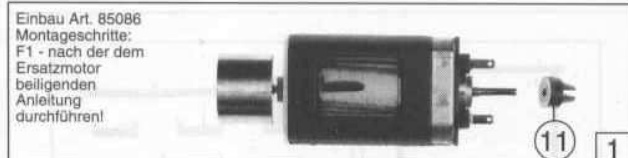

46 a. Abb. / no ill. Drehgestell komplett Bogie assembly 2
49 a. Abb. / no ill. Drehgestellboden Gear bottom
50 a. Abb. / no ill. Drehgestellrahmen Bogie frame

